



BWF-Certifire
Fire Doors and Doorsets

Installation Guide



1 *introduction*

- Managing risk
- Maintaining certification – the fire door label
- Maintaining certification, every step of the way
- The Building Regulations
- Standards
- Regulatory Reform (Fire Safety) Order 2005
- Regulation 38
- Qualifications for installing fire doors
- Third party certification for the installation of fire door



Introduction

This Installation Guide has been prepared by the BWF-Certifire Scheme to provide industry guidance and the minimum requirements for the installation of fire door assemblies and fire doorsets for the UK construction market.

Scope of this document

This guide draws information from a range of best practice guidance, standards and regulations impacting upon fire door installation. Installation practices must always be adhered to as recommended by the fire door manufacturer and building designer (1).

The responsibility for ensuring that competent (2) tradespeople install the product is that of the project manager and builder.

- 1) A designer is an organisation or individual that prepares or modifies a design for any part of a construction project. Designers include architects, consulting engineers, interiors designers, temporary work engineers, chartered surveyors, technicians, specifiers, principle contractors, specialist contractors and some tradespeople. CITB guide to CDM Industry Guidance for Designers 2015.
- 2) Competence can be described as the combination of training, skills, experience and knowledge that a person has and their ability to apply them to perform a task safely. <http://www.hse.gov.uk/competence/what-is-competence.htm>



Why fire door installation matters

Installation of fire doors is as life critical as the product specification itself and should only be carried out by someone who is competent, has been specifically trained to install fire doors and understands their responsibilities in getting it right.

Fire doors that are incorrectly installed and fitted with incompatible components invalidate certification and will not provide adequate protection for occupants or the building.

This guidance is a step by step process of the installation of a fire door. The guidance has been structured to allow understanding of both the installation of a door assembly and a doorset and to ensure that certification is maintained every step of the way.

Note: While every effort has been made to ensure the accuracy of advice given, the BWF cannot accept liability for loss or damage arising from the use of the information supplied in this publication. All internet links are current at time of publication.



Guide to symbols

There are easy to recognise symbols to support you at every stage and highlight checks and risk areas.

 COMPLIANCE WARNING Compliance Warning	 CHECK THE FIRE CERTIFICATE Check the Fire Certificate
 BEST PRACTICE Best Practice	 SAFETY WARNING Safety Warning
 COMPONENT COMPATIBILITY Component Compatibility	 INSTALLATION INSTRUCTIONS Installation Instructions
 TOP TIP Top Tip	



Managing risk

A minor mistake in fitting has dangerous consequences. If you install a fire door incorrectly there are 4 main risks:

- 1) The fire door will not perform in the event of a fire, causing fire and smoke spread through the building, creating danger to the occupants and firefighters responding in an emergency
- 2) The building is not properly protected and property insurances may be invalidated
- 3) If you are legally responsible for ensuring that fire doors are installed correctly you are liable and can be prosecuted if it is proved that they are incorrect
- 4) The certification of the fire door is INVALIDATED and you have no guarantee that the product will perform in a fire.

All fire doors supplied through the BWF-Certifire scheme are provided with installation instructions that are specific to the product. Installation methods and materials can change depending on a number of factors, including product type and installation environment.

Always follow the manufacturer's installation instructions to ensure that certification is maintained and the product will perform in a fire.



Maintaining certification – the fire door label

The BWF-Certifire label provides traceability through the supply chain, ensuring the manufacturer can always be contacted if further information on the fire door is required. The label is located on the top edge of the doorleaf and should never be damaged, painted over or removed from the door.

The label displays the manufacturers contact details and the certification number (CF or CAF). Each label has a unique serial number to provide full traceability back through the supply chain.

The installation instructions relating to the specific door can be sourced from the manufacturers and reference is also found in the fire door certificate (CF or CAF).

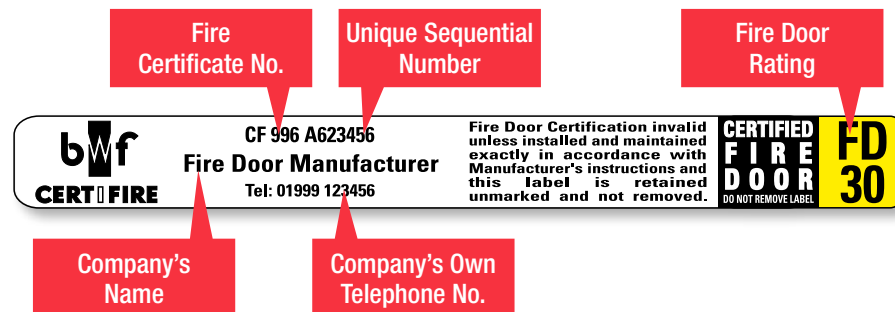

Labels should NEVER be removed from the door



Maintaining certification, every step of the way

Fire **DOORSETS** are supplied with their frames, manufactured to size, with all machining completed under the factory production control process to ensure accuracy, so there is little preparation required before installing the frame in the aperture.

Fire doors that are installed as **ASSEMBLIES** may require resizing and machining for component such as ironmongery or intumescent and smoke seals.

Always ensure that all components are compatible with the certification of the doorleaf. You can check the manufacturer's instructions and the fire door certificate (CF or CAF) for specific installation instructions. Do not use any incompatible fixings or installation materials as this will invalidate certification.

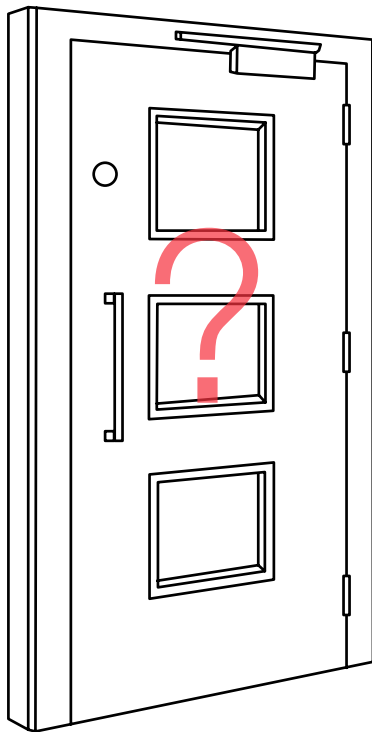

Doorsets

Complete unit consisting of a door frame and a door leaf or leaves, supplied with all essential parts from a single source.

BS EN 12519

The Fire Door certificate (CF or CAF) will list all compatible components and installation methods.

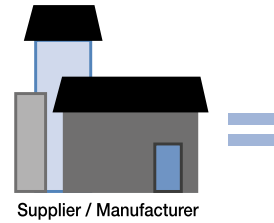

Door assemblies

Complete assembly as installed, including door frame and one or more leaves, together with its essential hardware supplied from 'separate sources'.

BS EN 12519

The Fire Door certificate (CF or CAF) will list all compatible components and installation methods.

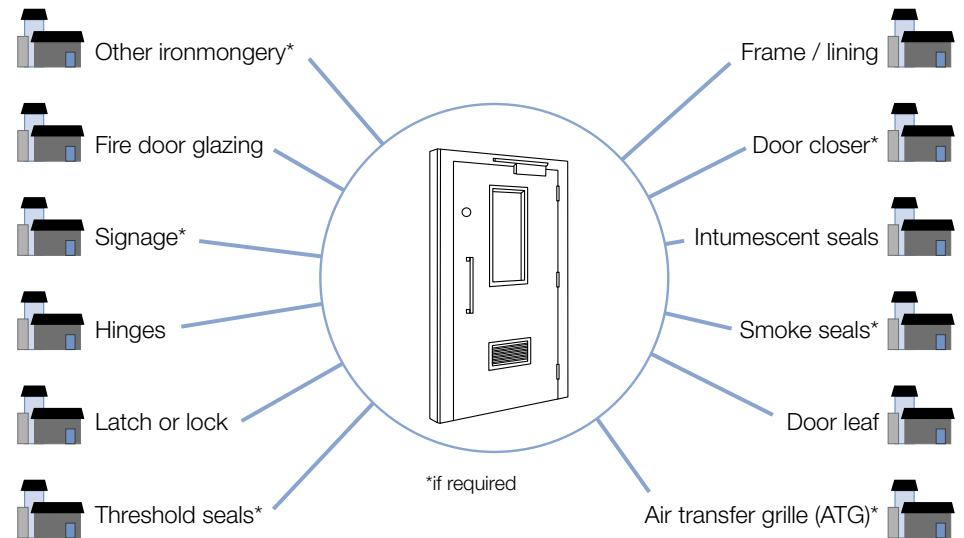

Regulation and standards and competency relating to the installation of fire doors

The Building Regulations

The Building Regulations currently do not include guidance about who could be suitable to install fire doors, however Approved Document B does state:

“Since the fire performance of a product, component, or structure is dependent on the satisfactory site installation and maintenance, independent schemes of certification and accreditation of installers and maintenance firms of such will provide confidence in the appropriate standard of workmanship being provided.”



See full information on Building Regulation guidance relating to fire safety in BWF-Certifire Best Practice Guide, available from bwfcertifire.org.uk

Regulations that relate to fire doors in England include:

- Approved Document B - Fire Safety Volume 1 and 2
- Regulation 7 - Materials and workmanship
- Approved document E - Resistance to sound
- Approved Document M - Access and use of buildings.
- Regulation 38 - the handover of fire safety information which will assist the responsible person to operate and maintain the building or extension with reasonable safety.

In other parts of the UK there are equivalent documents.

Standards

Installers of timber fire doors and those responsible to oversee the installation of fire doors should be familiar with BS 8214: 2016 Timber based fire door assemblies. Code of practice.

This standard is referenced in most fire door certificates and provides further information about fire door installation relating to different wall types, linear gap seals, and installation scenarios.

There are numerous other British and European Standards relating to the manufacture, testing and specification of fire doors and their related components.

Regulatory Reform (Fire Safety) Order 2005

The RRO, the Fire (Scotland) Act 2005 [5] and the Fire Safety Regulations (Northern Ireland) 2010 [6] in respect of the requirement for all buildings to be subjected to ongoing fire risk assessment, in which fire doors should be regularly maintained and inspected to ensure performance in a fire.

Regulation 38

Regulation 38 is a requirement under the Building Regulations for England and Wales to provide fire safety information to the 'responsible person' at the completion of a project, or where the building or extension is first occupied.

Regulation 38 requires that a package of fire safety information – 'as built' information which records the fire safety design of the building or extension – must be assembled and given to the 'responsible person' for the premises.



Qualifications for installing fire doors

In October 2017 the renewed Fire Door NVQ was launched in partnership between the British Woodworking Federation and Neath Port Talbot College. Contact BWF for more information.

The aim of this qualification is to draw attention to the specific knowledge and skills needed to install a fire door safely and is available as a standalone unit as part of the wider bench site joinery and shop fitting qualification.

Third party certification for the installation of fire door

There are a number of third party certification schemes relating to the installation of fire doors and this requirement is often included in the terms of some installation contracts.

This means that third party installers undertake specific training and are subject to annual audits and random surveillance site inspections by a UKAS accredited body. Proof of third party certification of installation is provided by a certificate detailing the company or individuals who are accredited and their scope of works.

All third party installers are expected to install only certificated or tested and approved products within their approved field of application.



The British Woodworking Federation provides the Fire Door Installer Register, a list of fully accredited third party fire door installers. Full details available here: www.firedoorinstaller.co.uk



2 *before you start*

- Planning the installation
- Before you start
- The linear gap seal
- Linear gap seal system checklist
- Delivery and storage
- Buying the door



Planning the installation

If you are a site manager or responsible to oversee the safe installation of fire doors there are a number of checks that you must carry out before the installation process and this will help you manage a seamless and accurate installation.

Before you start checklist

- **Product certification and compatibility**
All products that are to be installed are compatible with certification of the specific door or doorset that you are installing and listed on the relevant fire door certificate (CF or CAF).
- **Documentation**
You have access to specific manufacturer's installation instructions relating to the specific product that you are installing and that you have access to BS 8214:2016 Timber fire door assemblies – Code of Practice.
- **Wall type and building fabric**
A detailed survey should be undertaken to understand the wall type, construction and size of aperture. This will allow you to ensure that you have the correct fixings and fire stopping linear gap materials available at the time of installation.
- **Linear gap seals**
The backfilling of the linear gap between the frame and the wall should be considered. Use materials and methods detailed on the manufacturer's instructions.
- **Wall apertures and fitting tolerances**
Wall apertures should be checked to ensure that they are square and wall facings are level, before any product arrives on site to be fitted. Door frames and doorsets are supplied with a fitting tolerance. This is the size reduction that allows the frame to be located square and plumb in the aperture.

- **Finished floor height**
The finished floor coverings may not be installed at the time of fire door installation, so it is important to know the thickness of any additional floor covering (including underlay) that will affect the overall height of the frame and door. Confirm any tolerances between the head of the door and the frame and the bottom of the door and the floor, and ensure that these gaps are accounted for this at the time of installation.

- **The undercut**
The term undercut refers to the additional length that is sometimes added to the bottom of the frame stiles and bottom of the door leaf, to allow for installation scenarios where the final floor coverings are not in place, or the final thickness of floor coverings is not known at the time of ordering product. The undercut allows removal of material to account for this. The undercut dimension should be checked prior to starting any installation.

It is important to ask for information regarding the floor coverings and undercut, to ensure that excessive material is not removed by installers on site, and that the frame is installed at the correct height within the aperture, to allow for any further installation of floor coverings that may happen in the build process after the fire door has been installed. See page 19.

- **Gaps**
The gaps between the door and the frame around the perimeter of the doorleaf are critical to fire door performance. Ensure that you know the compatible gaps and tolerances before you start by checking the manufacturer's instructions. **Exceeding gaps invalidates certification and affects performance in a fire.**
- **Fixings, fire stopping linear gap materials and packers**
You should ensure that correct fixings, fire stopping linear gap materials and packers are available for the installation that are listed on the manufacturer's instructions and fire door certificate (CF or CAF).

- **Access**
Access to site needs to be planned before any product arrives to ensure that there is safe and sufficient access for installers and that the area can be protected from other trades whilst the installation is taking place.
- **H&S**
Consideration must be given to maintaining a safe environment for your workforce. The correct risk assessments, method statements and insurances must be in place before installation commences.
- **Competency of workforce**
Checks should be made to ensure a minimum level of competency of the individuals who will be installing the fire doors and products. A record should be kept of any specific training or qualifications that they hold.
- **Information from subcontractors**
Documentation provided by your subcontractor's should include method statements, copies of relevant insurances, proof of qualification, training or and other relevant competencies.
- **Create the Fire Door Register**
Many buildings will have a fire door register that records information and the history about each individual fire door. The fire door register is important as it provides a central hub for all the relevant information about the fire doors within a building. It can also record a multitude of information about the installation of each fire door.



Fitting doors into existing frames

Fitting new fire doors into existing frames is risky because the existing frame may not be fit for purpose or compatible with the certification of the new fire door leaf. If you are fitting new fire doors and components into existing frames there are a number of checks that should be made on the frame before taking the decision to only upgrade the doorleaf. If it is not compatible then certification becomes invalid.

The existing frame must be checked in accordance to the frame specification detailed on the fire door certificate (CF or CAF) to ensure that it is compatible.

Specification to check includes:

- ✓ That the correct installation including adequate fire stopping is in place in the gap between the existing frame and the wall (behind the architrave).
- ✓ The material (softwood or hardwood), species, density and the moisture content is listed as compatible on the fire door certificate (CF or CAF).
- ✓ The overall size and profile is listed as compatible on the fire door certificate (CF or CAF).
- ✓ The overall size and profile of any doorstop is listed as compatible on the fire door certificate (CF or CAF).
- ✓ That material removed from the doorframe for previous ironmongery will not affect the certification of the new fire door leaf or ironmongery.



The Linear Gap Seal

Planning the linear gap seal

- The linear gap seal refers to the method and materials used to fill any gap between the back face of the frame and the wall.
- Door assemblies should be installed as stated in BS 8214:2016 Table 2 for FD30 installations and Table 4 for FD60 installations.

or

- Suitable CERTIFIRE approved linear gap sealing systems may also be utilised to protect the frame/ supporting construction gap, subject to the conditions contained within the relevant certificate.

Before commencing installation, consideration should be given to sourcing the correct and compatible linear gap seal materials and methods.

There are a number of variables that will impact on the choice of linear gap sealant systems. Only use the system that is compatible to your specific installation scenario.

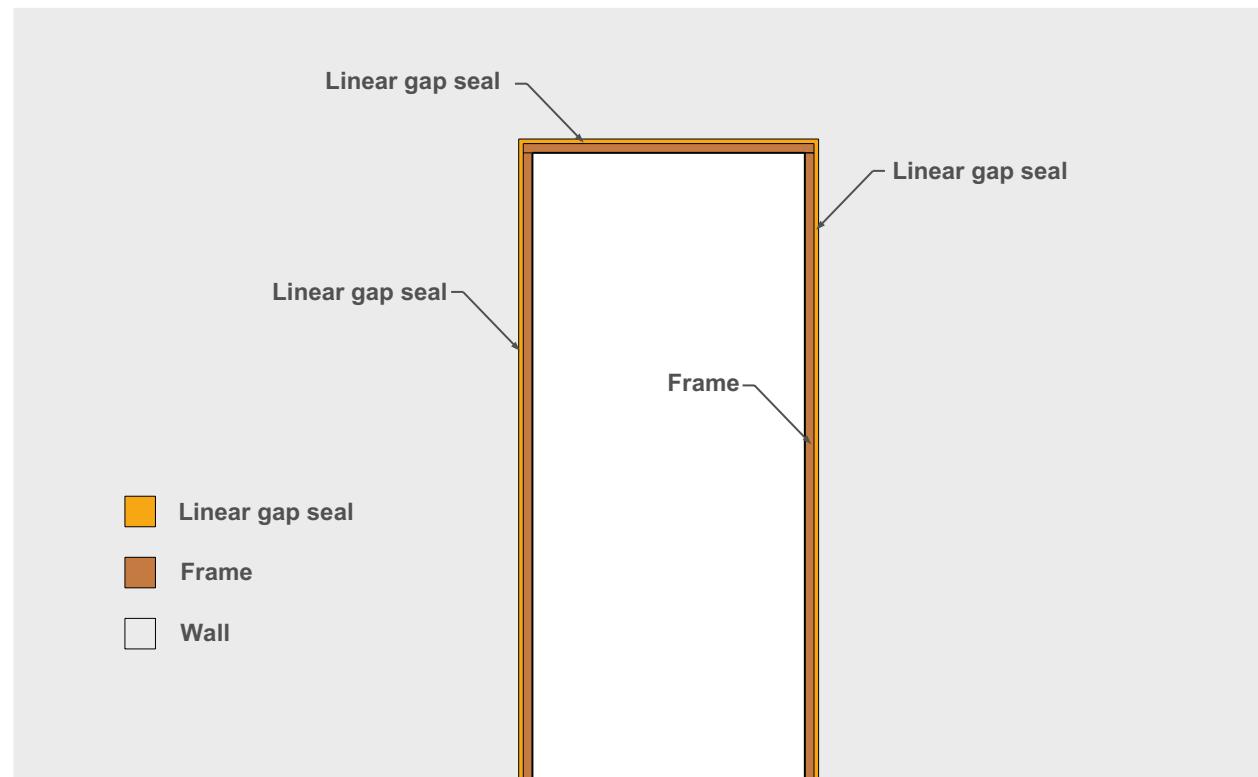

Linear gap seal system checklist

The variables that impact on choice for linear gap seal system include:

- The fire resistance of the installation (FD30 or FD60): Only use linear gap seal systems that are equal to or greater
- Wall type construction and material of frame: Only use compatible systems that have the specific combination listed on the compatible linear gap fire certificate or in the manufacturer's instructions
- The width of the gap between the back face of the frame and the wall: Linear gap seal systems are limited by the width of gap. If your gap exceeds these limitations, and you use an incompatible system, you risk poor performance and invalidation of certification
- Consider if the chosen linear gap seal system requires an unbroken capping of intumescent mastic around the perimeter to protect against smoke leakage. If this is the case ensure that packers are correct length and material to allow for capping
- If the gap requires an infill of 'backing material' – correct compatible material specification.

The linear gap seal

Who needs to be aware?

- Ensure that all contactors that are involved with the installation of fire doors and the installation of linear gap sealing systems are aware of the chosen method and materials. These jobs are often completed by different individuals, at different times of the installation.

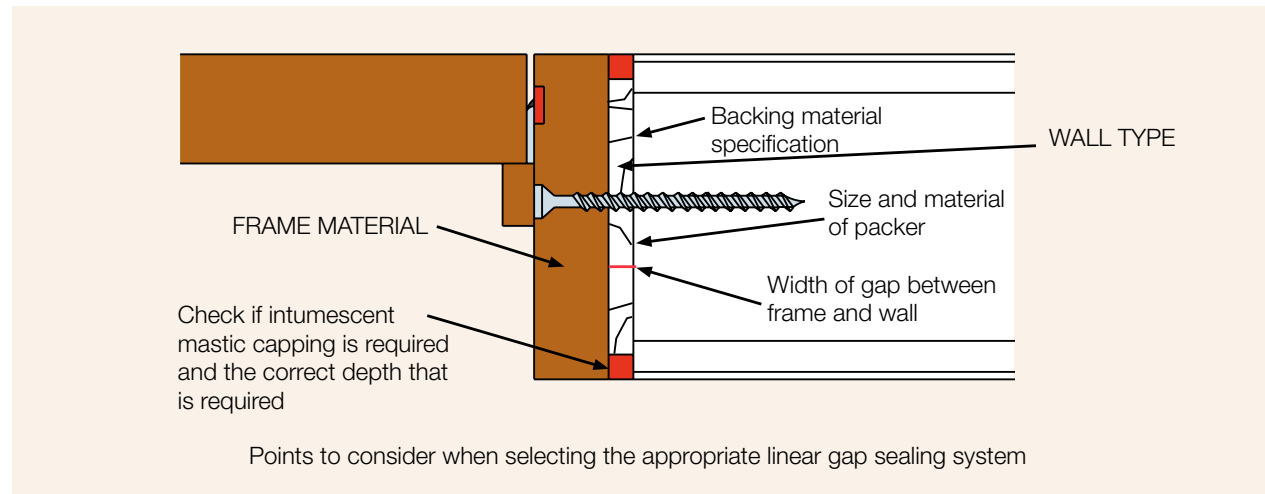

Checks to be made

Throughout the installation and linear gap sealing system process checks need to be made. These should include:

- The correct materials are being used and have not been substituted on site for an incorrect specification
- The workmanship is of a high standard and there are no gaps in the linear seal
- There is full sealing around the entire perimeter
- The correct gap is maintained between the frame and the wall to allow for the compatible and chosen linear gap sealing system. (complete perimeter)
- That the frame is centrally fitted in the wall opening to ensure the equal gap is maintained on both sides of the frame.
- Make the same checks on the gaps between the head of the frame and the wall construction above.
- Highlight if the packers require a capping of intumescent mastic across the face of them and check that they are fitted in the correct location
- Ensure that the packers are the right material and dimension to allow for the correct depth of mastic.
- Check that the installation of backing materials or other fire stopping materials

Many installers photograph their work in progress and record evidence to prove that the installation has been done correctly.

Remember that this gap is difficult to inspect once the architrave is installed without invasive inspection.



Delivery and storage

Care of product on site

Installation of fire doors should be left until the latest possible moment in the overall build. Fitting doors and their components too early in the build schedule can make the product susceptible to damage on site. Rapid changes in moisture content as the building dries out can affect the overall size and stability of product, and the critical gaps between the doorleaf and frame. It is highly recommended to schedule delivery of product so that they are not stored on site for extended periods of time prior to installation.



Delivery

- Fire doors are heavy. Make sure that there is sufficient facilities to manage doors and components
- Ensure that contractors are trained in manual handling heavy objects and that a record is kept of any relevant training
- Doors must be lifted evenly and securely to avoid any bending or damage of components or frames
- Protective wrapping should be kept in place as long as possible
- Paint grade doors should be sealed and primed on all faces and edges immediately after delivery. Do not paint over the BWF-Certifire label.

Storage

If products are to be stored for a minimal time prior to installation, strict environmental conditions must be met to ensure quality of product.

- Do not store in damp or exposed areas or near standing water, in direct sunlight or areas where there may be exposure to significant heat
- Stored flat, on a level and dry surface and kept clear of the floor on at least three level and robust bearers
- Protected from dirt and damage but without restricting air circulation and stacked so that they are not exposed to daylight as ultra violet light can cause fading or discoloration of timber and veneers
- Stored in the sequence they will be fitted to avoid double handling and avoid dragging them across each other in the stack
- Doorsets with projecting sills must have spacers between them in the stack to avoid damage.

Care of fire doors on site (pre installation) - Moisture content of timber doors

For long term performance of the door and finish, the appropriate moisture content must be maintained during storage on site and during the installation process. Rapid changes in moisture content and humidity can



affect the product. Product should only be installed once the site conditions (moisture levels and temperature) are suitable and similar to the conditions that the product will experience in service.

- Ensure that the moisture content of the product is kept close to the level at which it was when the door was manufactured.
- Storage on site should be kept to a minimum.
- Checks should be made on the building to ensure that moisture levels and temperature are similar to what the product will experience in service.
- Internal doors should be conditioned slowly to the service conditions before fitting.
- Protect from abnormal heat, extreme dryness, humid conditions or sudden changes of temperature or humidity
- Do not store or fit in the building until the wet trades are finished and the building has dried out.

Top tip: Do not store in damp or exposed areas or near standing water, in direct sunlight or areas where there may be exposure to significant heat



Buying the door

Check your product at point of purchase, collection or delivery

- ✓ Check product is undamaged
- ✓ Check for the BWF-Certifire label
- ✓ Check that order is correct and complete and all compatible components of the assembly or doorset have been delivered
- ✓ Clean the location of fitting
- ✓ Carry out a risk assessment and method statement regarding installation
- ✓ Ensure that those fitting the fire door assembly or doorset are correctly trained, specifically about fitting fire doors and understand their responsibilities.

NOTE: ORDER THE RIGHT DOOR: Altering the door for glazing apertures and air transfer grilles or resizing outside of the parameters on the certificate will make certification **VOID**.

Prefinished Doors

- Factory finished door frames or door linings should ideally be fitted into pre-formed openings and not built into masonry walls
- Pre-finished doors should retain their protective packaging until the latest possible time, ideally until after internal decorations have been completed
- If it is necessary to separate the doors from doorsets, each door and frame should be given an identification mark so that the correct door is returned to the correct frame

Finishing the edges of fire doors

Changes in moisture content can affect the size and shape of a door and all edges (sides, bottom and top) should be coated to prevent moisture from penetrating the timber.



NOTE: The BWF-Certifire label should not be painted over.

Finishing doors on site

- Decoration should be started as soon as possible after delivery, doors with factory applied primer should have at least one of the finishing coats applied as soon as possible after delivery or installation
- The back of external frames should be coated before installation
- Ensure surfaces and edges are in good order before applying finishing coats
- Ensure all surfaces and edges are painted
- The edges should be coated before fitting the door
- The label that identifies the fire door must NOT be painted over
- Damage or defacing the label will result in the door no longer being accepted as a fire door

For additional and specific guidance for your product, contact your fire door supplier.



3 *installation process*

- Pre installation checklist
- The installation process – best practice
- Preparing the door leaf
- Fitting the door closer
- Post installation checklist
- Handover of information
- Fire doors inspection maintenance
- Glossary
- Sources of further information



Pre installation checklist

Wall type: Of suitable fire resistance for the fire door assembly or doorset rating.	✓
Installation Instructions: You have the relevant installation instructions from the manufacturer.	✓
Linear gap seal: You have suitable materials and intumescent materials and mastics to fill the gap as detailed on the installation instructions or fire certificate data sheet.	✓
Door leaf: Suitable for the fire door rating. Free from damage. BWF-Certifire label/s on top of door undamaged.	✓
Door frame: Free from damage. Suitable for the fire door rating.	✓
Compatible with the door assembly or doorset.	✓
BWF-Certifire label/s on frame (if applicable) undamaged.	✓
Fire and smoke seals: Free from damage. Suitable for the fire door or smoke rating.	✓
Compatible with the door assembly or doorset.	✓
Fixings: You have appropriate fixings for the frame, hinges, lock, latch and other ironmongery as specified by the manufacturer.	✓
Ironmongery: Supplied with correct intumescent pads. Supplied with fitting instruction.	✓
CE marked for fire performance where applicable. Hinges free from damage.	✓
Suitable for the fire door rating.	✓
Compatible with the door assembly or doorset.	✓
Vision panels or other apertures cut in the door leaf for ironmongery such as letter plates or air transfer grilles: Check all ironmongery, glass, glazing beads, seals and intumescent materials are free from damage and secured to the door.	✓
BWF-Certifire label: Check door label /s in place.	✓
The linear gap seal method and materials has been checked and agreed, suitable for the specific installation scenario.	✓
Health and safety: You have carried out a thorough risk assessment of the installation process and limited any risks.	✓
Competency of workforce: Ensure your workforce are suitable trained and qualified to install fire doors.	✓

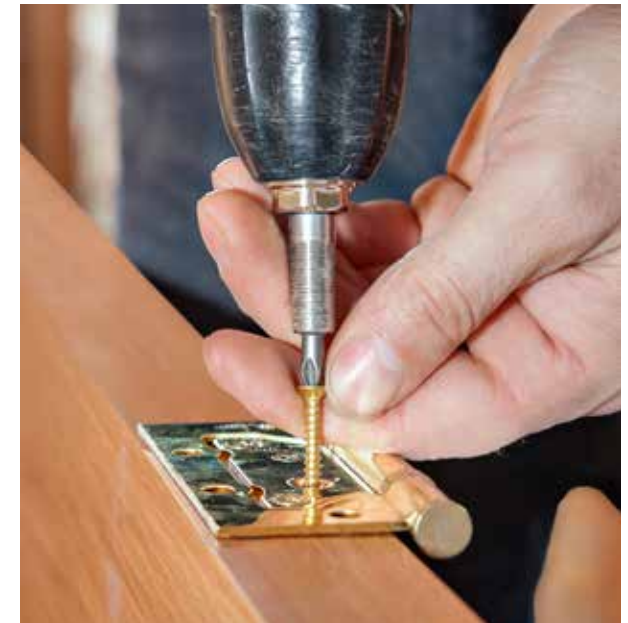

The installation process - Best Practice

Preparing fire door components for fitting - general guidance

The best practice advice in this section has been developed to aid the installation process of both fire door assemblies and fire doorsets. Some of the operations detailed are not relevant to the installation of fire doorsets because these operations are completed by the fire door manufacturer, under a strict factory product control system, prior to the delivery to site.

This advice has been developed to complement the specific manufacturers installation instructions and should not be used in isolation or as a substitute for them.

Always follow the manufacturers instructions to ensure that certification is maintained.

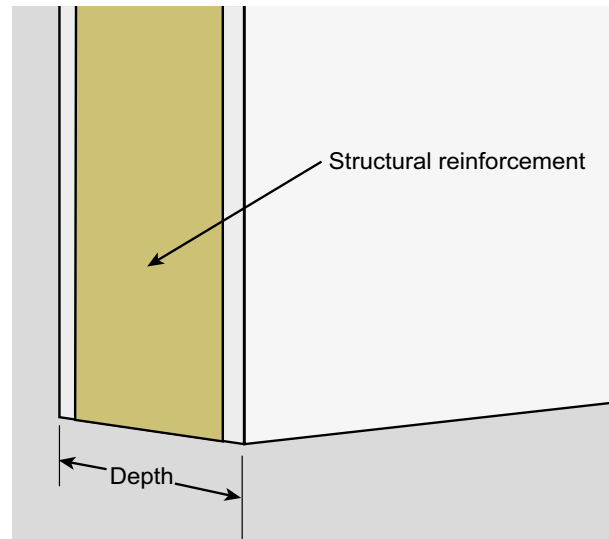

- Ensure the work area is clear, protected from other trades and clear of any debris
- Check the aperture is square and plumb level and has sufficient tolerance to enable the frame to be located accurately, without distortion
- Check that any structural reinforcement such as stud work and aperture linings are in place within the wall construction (jamb, head and threshold) before you start. The size of compliant structural reinforcement is given in the specific fire door certificate
- Check that you are fitting the correct door in the correct aperture. All doorsets or door component should be labelled with their location
- Ensure that you have the specific manufacturer's installation instructions to hand to reference throughout the installation
- Check the overall size and depth of the aperture and confirm that the product that has been supplied is correct.

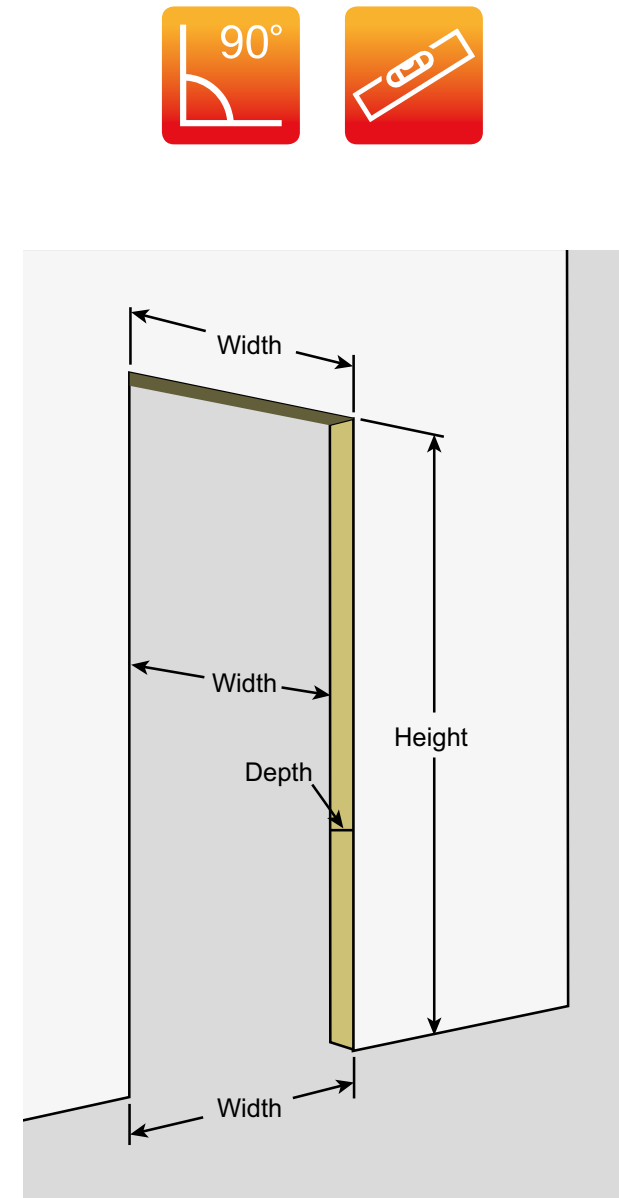

Setting out the frame size

- Confirm the finished sizes of the frame in relation to the doorleaf size, wall aperture size and required fitting tolerances. Take into account the gaps required between the door and frame and the finished floor height
- Confirm the finished floor height if it is not in place when the frame is installed. Account for this in any modifications made to the overall frame height
- Undercut: The term undercut refers to the additional length that is sometimes added to the bottom of the frame stile and bottom of the door leaf, to allow for installation scenarios where the final floor coverings are not in place, or the final thickness of floor coverings is not known at the time of ordering product. The undercut allows removal of material to scout for this. The undercut dimension should be checked prior to starting any installation
- It is important to ask for information regarding the floor coverings and undercut, to ensure that excessive material is not removed by installers on site, and that the frame is installed at the correct height within the aperture, to allow for any further installation of floor coverings that may happen in the build process after the fire door has been installed.

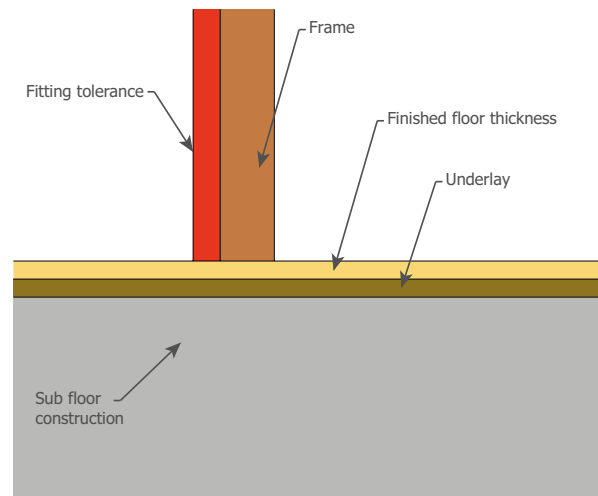
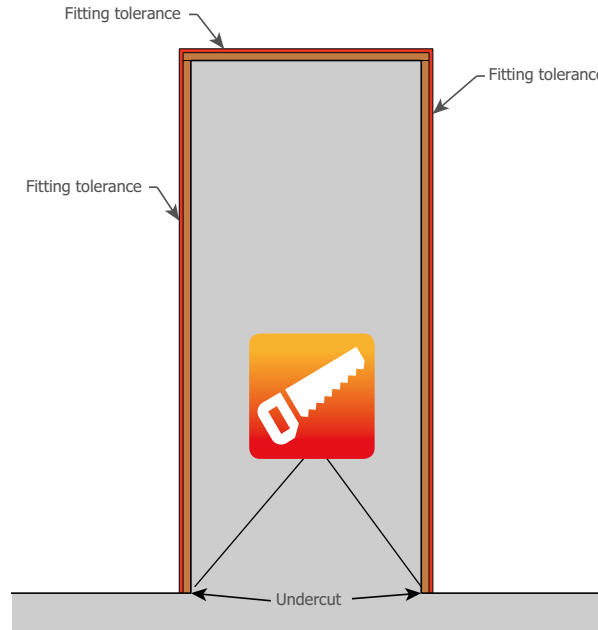

Setting out the frame for ironmongery and seals

- The shoulder of the joint at the top of the stiles of the frame should be used as the datum. Always work from the top down to set out frame components in their correct position. Take into account the gaps required between the door and frame
- If this is done on site, it is recommended that all frame resizing and machining for components is completed before the frame is assembled to ensure accuracy
- All locations of intumescent and smoke seals, hinges, locks and other ironmongery will be specified on the manufacturer's instructions. Sometimes the seals are located in the frame or in the door leaf edge
- A minor mistake will invalidate certification and can affect performance in a fire
- Mark out the location for all machining required on the frame for hinges and if required, the lock or latch keep.
- Always work from the shoulder down and remember to account for any gaps between the top of the door and the frame, and the bottom of the door and the frame
- Ensure that the depth of machining allows for the inclusion of additional intumescent material or pads if required on the manufacturer's instructions.

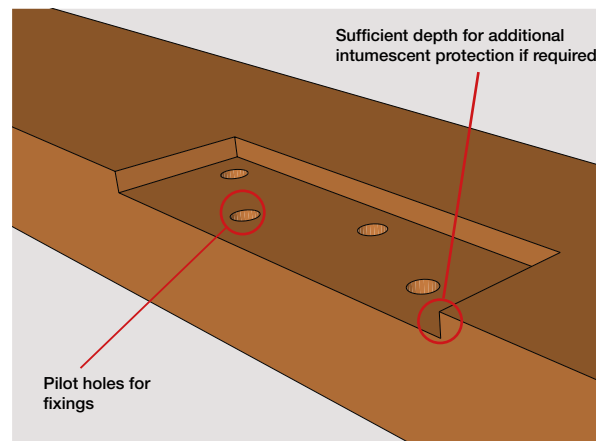
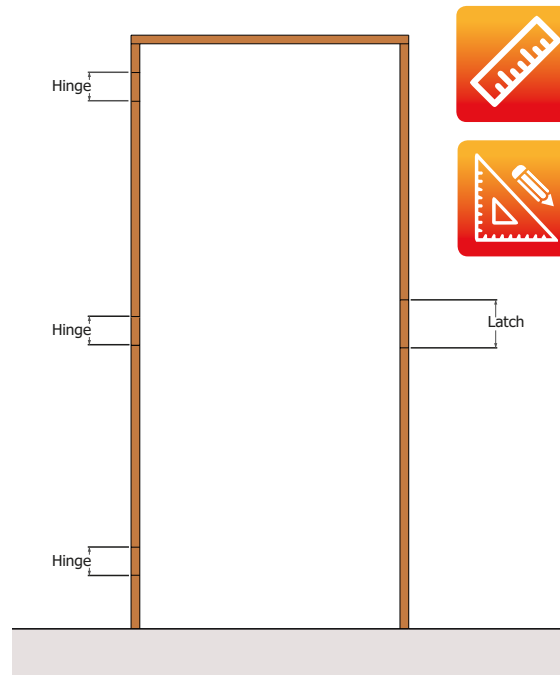

Machining the frame with grooves for intumescent and or combined intumescent and smoke seals

- Sometimes the seals are located in the frame or in the door leaf edge. Always check the manufacturer's instructions and only use compatible seals for compliance with certification
- Many installers would choose to only fit the compatible seals once the product has been fully finished on site. If this is the case, the thickness of any paint or other decorative finishes should be taken into account when machining the width and depth of the groove
- Check the manufacturer's instructions for the correct specification, position, size and depth of the grooves for intumescent and / or combined intumescent and smoke seal
- If the groove for the seals is located in the frame, machine the groove in the exact position specified on the instructions
- Remove any dust or debris from the groove and undertake checks for position and size accuracy, and compliance with the manufacturers instructions.

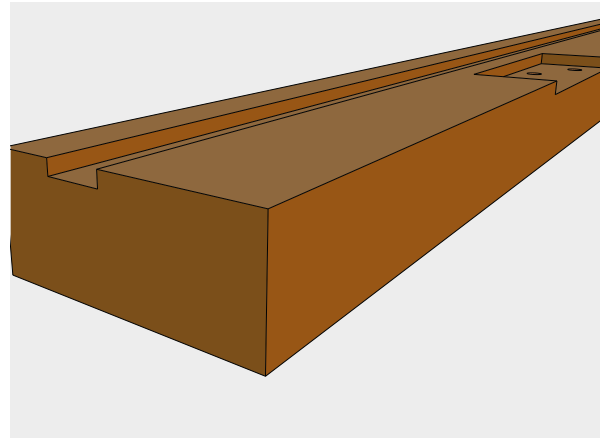

ALWAYS FOLLOW THE
MANUFACTURERS INSTALLATION
INSTRUCTIONS

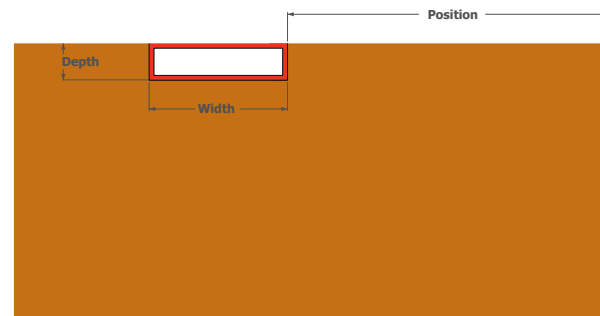

Fitting the frame with intumescent and or combined intumescent and smoke seals

- Seals are either located in the frame or in the door leaf edge. Always check the manufacturer's instructions for compliance with certification.
- Many installers choose to only fit the seals once the product has been fully finished on site. If this is the case, the thickness of any paint or other decorative finishes should be taken into account when machining the size and depth of the groove.
- Note that combined intumescent and smoke seals must not be painted over as this will affect the performance.
- Ensure that the make, material, number of and size of seals is compatible with the manufacturer's instructions and with the rating of the fire door and door configuration.
- Seal configuration is different for single or double doors and is specific to individual door certification. Always check the certificate for compatibility.
- Remove any dust or debris from the groove. Undertake checks for location accuracy and compliance with the manufacturer's instructions.
- Press the seals firmly into the groove (remove self-adhesive backing on seal and apply pressure full length of the seal to make sure it is secure).
- The face of the seal must be flush with the surface of the groove. (Including any additional paint decoration).
- The seals must be fitted in full length strips and be butted up closely in the corners, no gaps!
- It is not recommended to use any mechanical fixing to fix the intumescent into the groove.

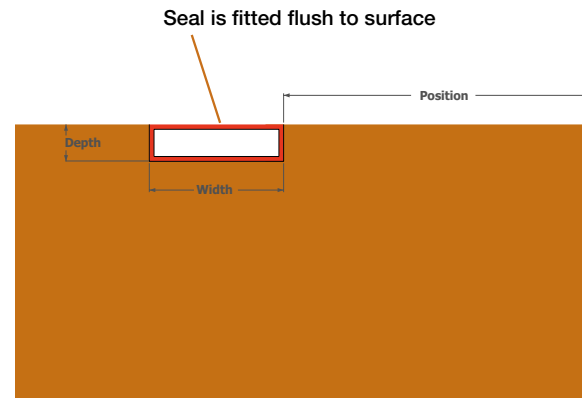

Cross section of frame with intumescent seal

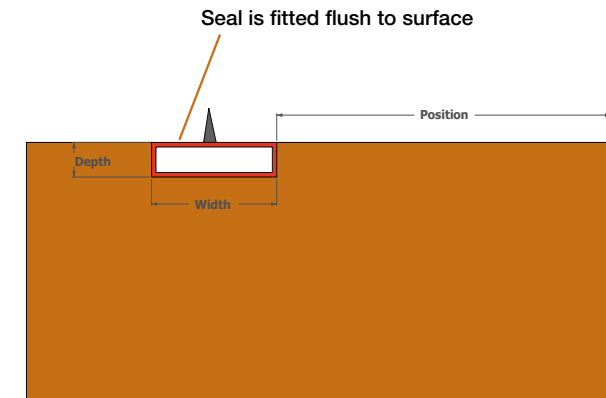

Cross section of frame with intumescent and smoke seal

Check:

- The entire perimeter seal to ensure that it is full length with no gaps or joins
- Fitted securely in the groove – full length
- Fitted flush with the surface of the groove
- Undamaged



Machining the frame with for hinges and lock / latch keep

- Always check the manufacturer's instructions and only use compatible components for compliance with certification.
- Many installers would choose to do final fix of the compatible ironmongery once the product has been fully finished on site. If this is the case, the thickness of any paint or other decorative finishes should be taken into account when removing material from the frame to accommodate ironmongery.
- Ironmongery often needs additional intumescent pads, jackets of materials fitted to perform in a fire. When setting out machining for ironmongery always ensure that tolerances are added to accommodate any additional intumescent protection.
- Always check the manufacturer's instructions to confirm if additional intumescent materials are needed, and to ensure the correct specification, size and thickness, and location.
- Do not exceed the maximum dimensions given for material removal on the manufacturer's instructions
- Check the manufacturer's instructions for the correct specification, location, size and depth for the hinges and keep.
- Check the additional thickness and materials for any additional intumescent materials required and include this in the setting out.
- Take into account the position of the doorstop and any doorstop smoke or intumescent seals (such as batwing smoke seal) that would affect the position of the hinges.
- Machine out in the exact position specified on the instructions.
- Remove any dust or debris from the groove and undertake checks for location and size accuracy, and compliance with the manufactures instructions

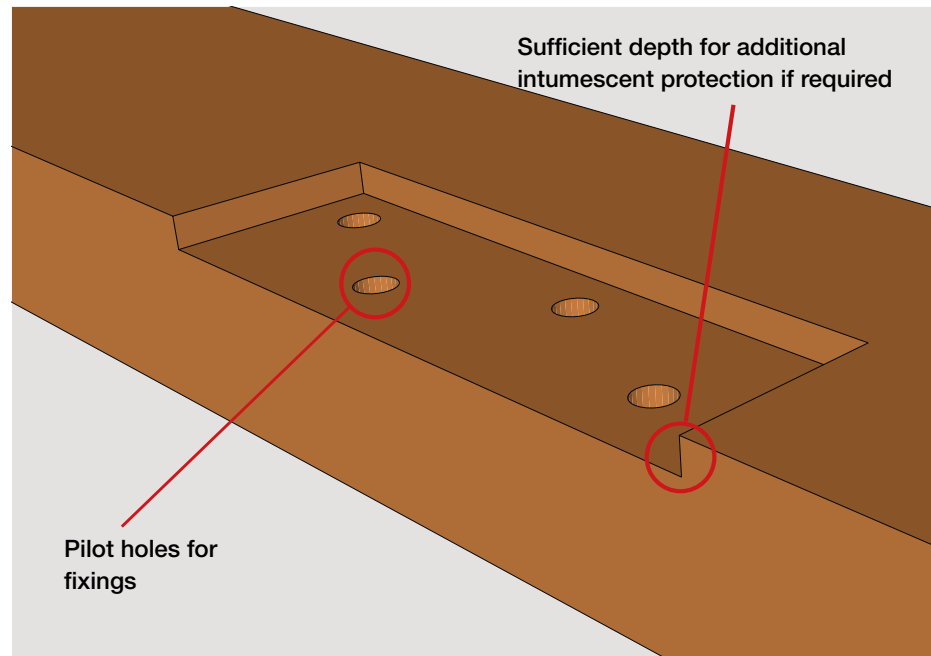

Jointing of the frame

- A rebated frame will require a joint on the top corners of the frame. The manufacturer's recommendations and fire certificate data sheet should be followed regarding types of compatible joints. Always work from the top down to set out frame height using the shoulder of the joint at the top of the jambs of the frame as the datum and make any height adjustments from the bottom of the jambs. See page 18 and 19.

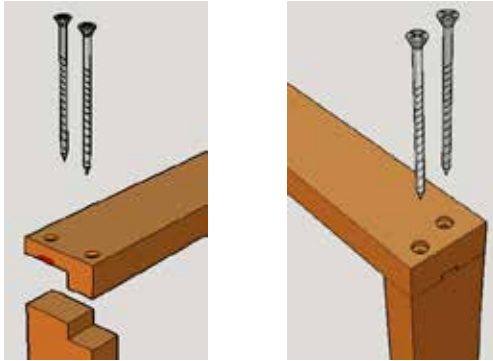

Assembly of the frame

- Before fixing the corners of the frame together countersunk pilot drill holes must be drilled to prevent timber from splitting
- The gauge, length and material of corner frame fixings must be as specified on the manufacturer's instructions.
- Fix the corners of the frame together using the specified fixings, adhesive and methods detailed on the manufacturer's instruction
- Check that all joints are tight, square, secure, and robust and remove any loose fibres for a neat finish.
- Check that the frame is square, if adhesive is used, allow time for this to cure, and ensuring then the frames are laid evenly on a level surface and are square.

Fitting ironmongery to the frame and door leaf

- Ensure that the correct and compatible mechanical fixings (screws) are used to fix ironmongery to the frame. Check the manufacturer's instructions to confirm the specification (size, length, gauge, material). The fixings should be supplied with the ironmongery product
- The location of ironmongery components on frame and doors is critical. Ironmongery components often need additional intumescent pads, jackets of materials fitted to perform in a fire
- When setting out machining for ironmongery always ensure that tolerances are added to accommodate any additional intumescent protection
- Always check the manufacturer's instructions to confirm if additional intumescent materials are needed, and to ensure the correct specification, size and thickness, and location

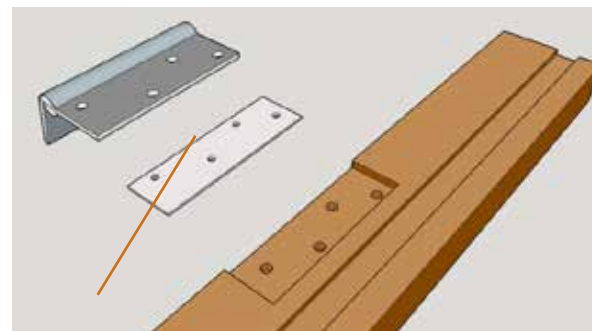

Intumescent protection where required under hinge blade

- Remove any dust or debris from the machined recesses
- Place the hinge or keep into the machined recess and check that it is in the correct location, securely located against the edges of the recess
- If additional intumescent materials, pads or jackets are required, ensure these are in location before you fix the component
- Pilot drill a hole suitable in size and depth for the compatible screw fixing, to prevent timber from spitting
- Secure the ironmongery with the screws, check that all screws are installed
- Do not overtighten the screws or damage the heads
- Do not exceed the size and depth limitations of material that can be removed from the doorleaf to accommodate ironmongery components such as the lock or latch as stated on the manufacturer's instructions.

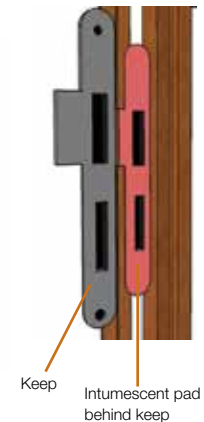
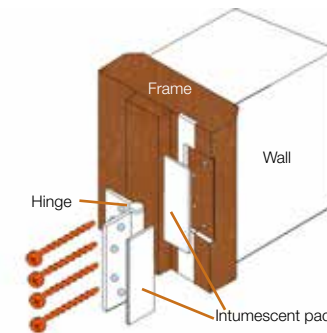

Face fixed additional ironmongery

Sometime additional face fixed ironmongery is required such as signage, door number, push or kick plates.

Additional checks should be made to confirm that the door is suitable to have the parts fitted and the correct length fixings are use that will not impact upon fire performance.

Check:

- ✓ All ironmongery has been fitted with intumescent pads, jackets of materials if required. Check the manufacturer's instructions to ensure compatibility with certification
- ✓ Fitted securely in the machined recessed and all screws are in place
- ✓ There is no damage to any components



Fitting of letterplates and other ironmongery into aperture cut-outs into the doorleaf



- **Cutting apertures on site invalidates certification**
- Some ironmongery such as letterplates and air transfer grilles may require final fitting on site in to pre made apertures in the door leaf.
- Prior to fitting ironmongery such as the air transfer grille cover plate or the letterplates, checks should be made to confirm the product is compatible with the certification of the door leaf and that it is the correct fire rating. Checks should also include the correct size and position of the aperture, the presence of timber aperture lining (where required), the correct and compatible intumescent protection such as the intumescent block behind the air transfer grille or the intumescent sleeve inside the letterplates. The correct fixings must be used as supplied with the product.



Preparing the door leaf

Ironmongery

- The compatibility of ironmongery must be in accordance to the manufacturer's instructions and the fire door certificate
- The manufactures instructions will give advice as the location of ironmongery components
- Where required, ironmongery must be fitted with its compatible intumescent protection, the manufacturer's instructions will advise where this is required and the specification.
- Follow the steps given earlier in this document to machine the ironmongery into the doorleaf
- All ironmongery should be fixed using the fixings supplied with the ironmongery.



Seals located in the door leaf

- Some fire doors require the intumescent and smoke seals to be located in a groove in the perimeter edge of the door leaf.
- In this case, reference should be made to the manufacturer's instructions regarding the specification, number of and position of seals.
- Follow guidance earlier in this document regarding machining of the intumescent groove.

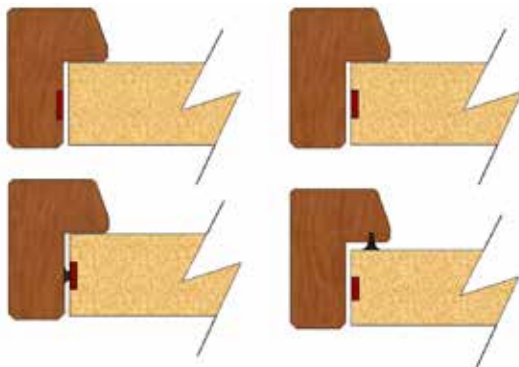

Resizing of the doorleaf

- A door leaf should only require minor resizing to fit the frame. Check the manufacturer's installation instructions for the maximum amount of material that can be removed.
- Material should not be removed from the top of the door leaf.
- The BWF-Certifire label/s should not be removed, damaged or repositioned as this will invalidate certification.
- Always check the manufacturer's recommendations

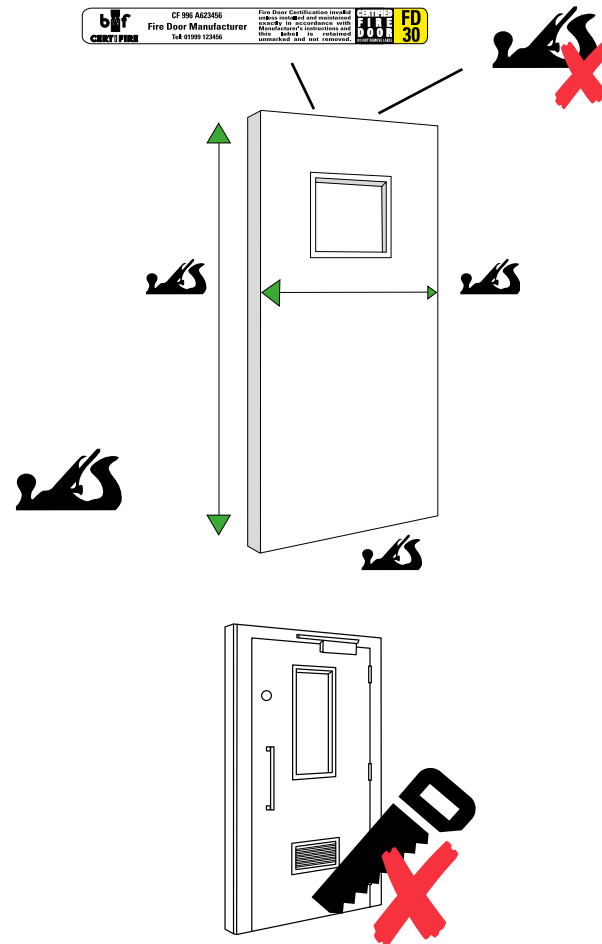

Apertures in the doorleaf

- Do not cut apertures on site as this invalidates certification. Apertures should only be cut by a licensed BWF-Certifire member to validate certification.
- Apertures in the doorleaf are sometimes required for glazing, letterplates, air transfer grilles, eye viewers or the fixing of other ironmongery
- Ensure the correct specification at the time of ordering product as adjustments cannot be made on site without invalidating certification.

Drop down threshold seals

Ensure the groove for any drop down threshold seal is in the correct position and to the correct dimensions.

- Use the fixings provided to install the component with any additional intumescent where required.
- Always lock the threshold seal in the closed position whilst hanging the door and only release when final overall checks of the doors opening action is tested. This reduced the chance of damaging the seal.



Fixings for the frame

Follow the manufacturers guidance regarding the material, length and number of screws required. In all other cases, steel screws (CE marked for structural use and specified in accordance with Eurocode 5) should be 5 mm in diameter wood screws with countersunk head. The screws should achieve a minimum depth into the wall construction of 70 mm once installed. Screws should be positioned and installed to ensure the frame components remain square and do not distort.

When metal components come into contact with some timbers that contain certain extractives, corrosion can occur. Checks should be made to ensure that fixings and frame materials are compatible.



Packers

- At each fixing point a packer needs to be inserted between the back side of the frame and wall.
- The packer must be exactly the same thickness as the gap to prevent frame distortion when fixed in place.
- The packer material and size must be in accordance to the specification detailed on the fire door certificate or within the compatible linear gap seal certificate.

If the specific material for the packer is not specified, then it should be of the same material as the frame.

- Be aware that many CERTIFIRE linear gap sealant systems as detailed on the relevant certificate require a 'capping' of intumescent mastic to be applied over the face of the packer (front and back). In this case the packer length should be reduced in length to allow for the correct depth fill of intumescent mastic on both sides.
- It is best practice to fix through the packer to secure it in place.

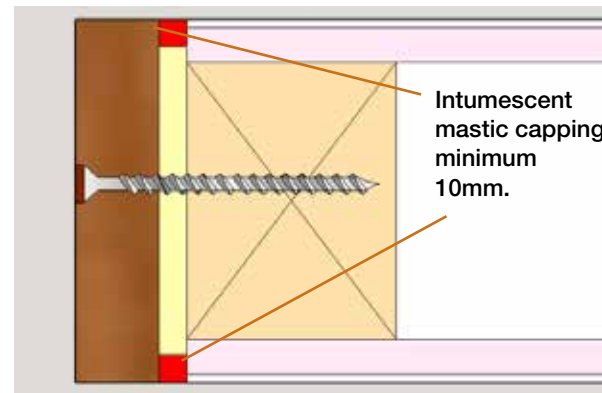

Specification of frame to wall fixings

- The specification of mechanical fixings should be compatible with the wall type.
- The fixings must achieve a depth of minimum 70 mm into the wall construction (excluding any fitting gap)
- The gauge of fixings should be a minimum of 5 mm (excluding any rawl plug or expanding fixing.)
- Pilot holes (5.5 mm diameter) through the frame should be drilled to accommodate the size of the fixing
- The pilot holes must be counter bore holed to ensure that the head of the fixing and any fixing flange is located below the surface of the frame
- The counter bore holed should be plugged with a compatible timber plug. The head of the plug should be finished so that it is flush with the frame surface.

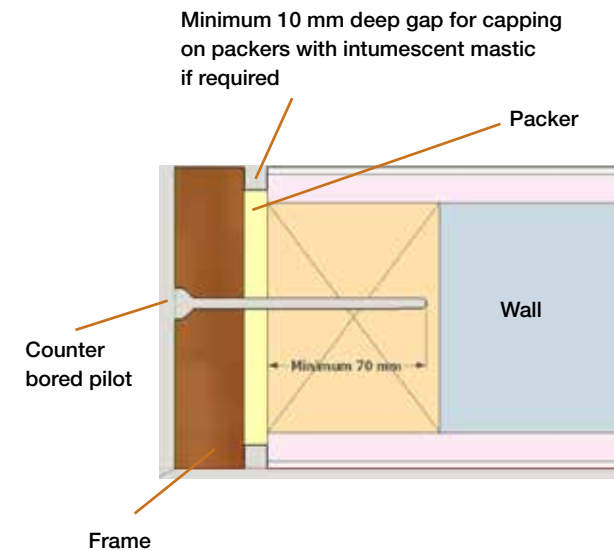

Preparing the frame for the wall fixings

- Before positioning the frame in the aperture, counter bored, pilot drill holes must be drilled to prevent timber from splitting
- The position and number of fixings required will be detailed on the manufacturer's recommendations. In all other cases the frames should be fixed at between 120 mm – 200 mm from the corners and at a maximum of 450 mm centres
- Drill a 5.5 mm diameter pilot hole through the frame and counter bore the top at each fixing location
- Remove any loose timber fibres from the edges of the hole with a fine grade finishing paper
- Fixing in the head of the frame – best practice is to follow guidance above regarding location and number of fixings
- Frames over 900 mm in width must have head fixings in accordance to manufacturers recommendations and information given above.

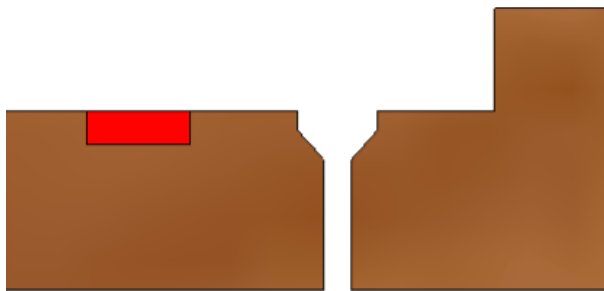

Cross section of frame with counter bored pilot hole and frame intumescent strip



Locating the frame in the aperture

- Position the frame centrally in the aperture, with equal fitting tolerances on both sides
- Check the correct height of the frame – this may change if you do not have final floor coverings in place. Use packers under the frame to achieve the correct height – these packers should be removed once final fixing has taken place
- Ensure that the frame is plumb level and square
- Ensure the frame is positioned to the correct depth within the aperture – take into account any decorative wall coverings that may not yet be installed
- Only use packers that are full depth of the frame, to ensure that frame components are not distorted as fixings are applied
- Loose fit any packer's between the back of the frame and wall at the fixing points already marked on the frame. Take care to use the correct thickness and depth of packer so that the frame is not distorted.
- Check that the dimension of the door frame aperture is sufficient to accommodate the width of the doorleaf plus any gaps either side
- Check that the height of the frame aperture is sufficient to accommodate the height of the doorleaf plus any gaps above or below the door
- Drill a pilot hole into the wall construction of a size and depth, suitable to take the fixing type.



Fitting Tolerance



Packer



Frame



Wall

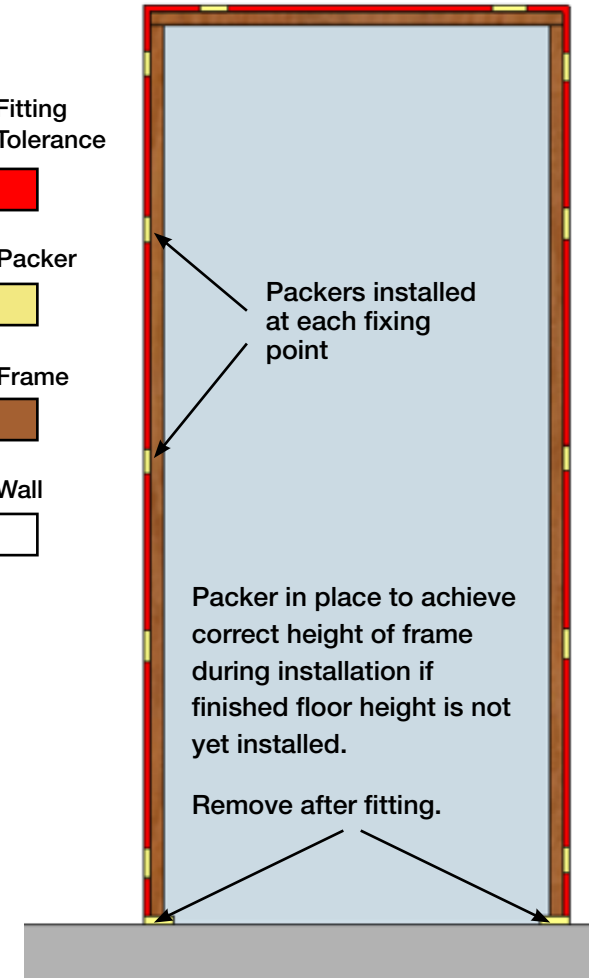

Fixing the frame

- Start on the hinge jamb at the top fixing. Insert screw through hole point. The fixings must achieve a depth of minimum 70 mm into the wall construction (excluding any fitting gap)
- Position the screw at the correct depth (including any raw plug or expanding fixing, by lightly tapping it with a hammer)
- Slowly do up the screw into its final position, taking care not to damage the head of the screw or over tighten it
- Ensure that the screw head is tightly against the frame and fixing is robust. Ensure the head of the screw is well below the surface to accommodate a timber plug above it
- Do not overtighten fixings, as this may cause the straightens of the frame sections to distort- the correct thickness and position of packers in the gap between the frame and the wall will prevent this
- After each fixing has been applied carry out checks to ensure that the frame is still in the correct position and is square and plumb level and that the frame is at the correct height to accommodate floor coverings
- Once all fixings are in place carry out checks to ensure that there is no distortion of the frame and that the frame aperture is exactly the right dimension (height and width) to accommodate the door leaf
- Remove any height packers and install timber plugs to cover fixings, Finish the plug flush with the surface.

NOTE: When metal components come into contact with some timbers that contain certain extractives, corrosion can occur. Checks should be made to ensure that metal fixings and timber materials are compatible.

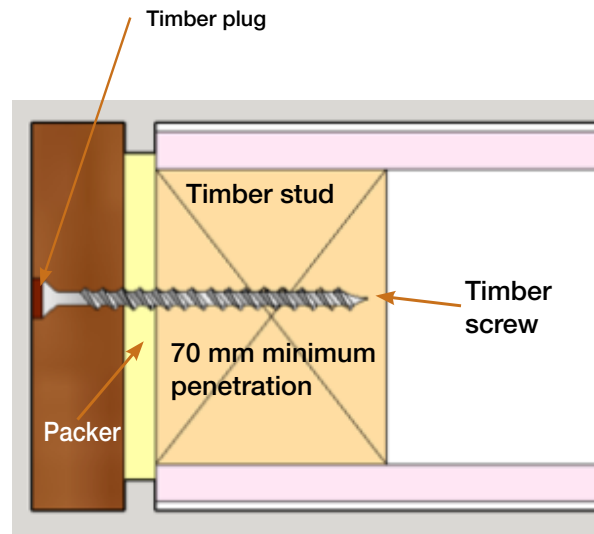

Cross section of frame fixed with packer to timber stud wall construction

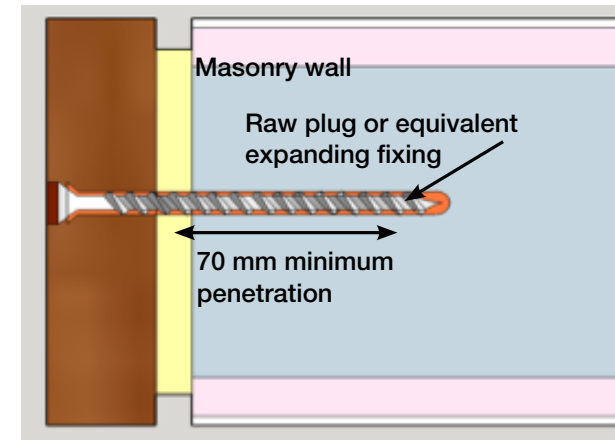

Cross section of frame fixed with packer to masonry wall construction



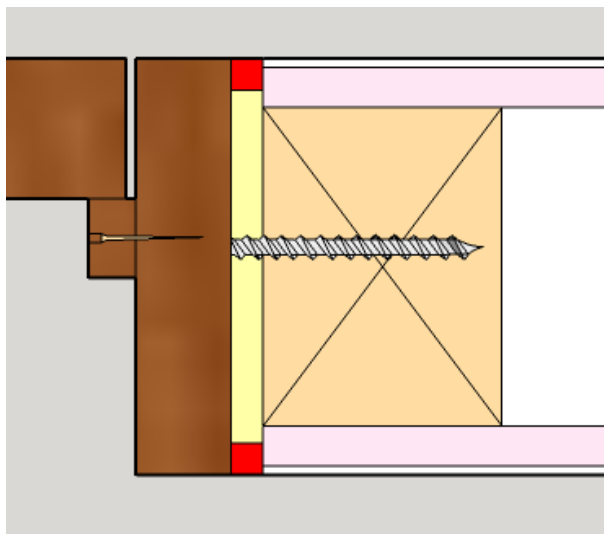
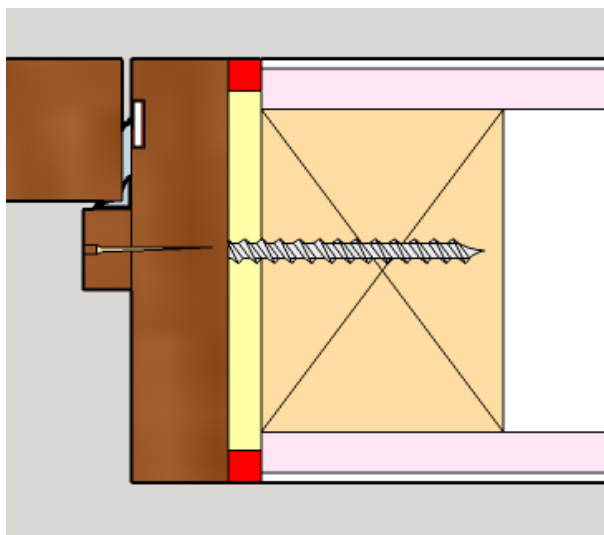

Fixing the doorstop

- Where the doorstop is supplied separately to the frame section, often the installer will choose to fix this once the door is hung. This helps to ensure that it is in the correct position in relation to the closed doorleaf position in the frame
- Check if additional smoke seals are to be fitted to the doorstop. If this is the case, apply these seals to the face of the doorstop before fixing the doorstop to the frame as this will ensure the correct position and gap required for the smoke seals to engage when the door is closed
- Doorstops must be fitted full length without breaks. In the corners the doorstop must be butted up tightly together with no gaps
- Follow the manufacturer's recommendations. In all other cases, doorstops should be fixed with adhesive and a mechanical fixing such as a 1 mm gauge steel panel pin that will achieve a minimum penetration of 25 mm into the main frame section.
- Some manufacturers have specific guidance regarding type of fixing required, always check the manufacturer's guidance for recommendations first.
- Position the doorstop against the face of the door in the closed position, starting at the top corner of the hinge side.
- Apply adhesive and fixings from the top down, ensuring that the doorstop is flush against the doorleaf in the correct closed position. Make checks at every fixing point
- Unless manufacturer provides guidance, doorstop fixings should be at 100 mm in from the corners of the frame and at a minimum of 250 mm centres
- Where there is a smoke seal doorstop in place, specific guidance should be sought from the seal manufacturer regarding the optimum gap between the door and frame in the closed position to ensure that seals are not over compressed or damaged in operation.
- Fixing heads should be finished below the surface to allow for filling with wax to match finish.



Hanging the door leaf

- Position the hinges into the hinge recesses created in the door leaf using the correct intumescent packers (where required) and the correct fixings supplied with the hinges
- Position the hinges into the frame hinge recesses and ensure that intumescent pads are used under the hinge blades as specified in the installation instructions
- Counter bore pilot holes to the correct diameter and length to suit the hinge fixings into the frame
- Apply 2 fixings at each hinge point into the frame
- Remove the packers at the base of the door taking care not to damage the door leaf
- Swing the door and check that it closes correctly in the frame and that the gaps around the door leaf are correct
- Apply the final fixings at the hinge points and repeat checks the fixings into the frame, ensuring that screws are not overtightened and the screw head is not damaged
- Check the correct gap between the door leaf and frame when the door is closed
- Check that the smoke seal is in contact with the frame/door leaf around the full perimeter when the door is closed
- Check that the drop down acoustic and cold smoke seal is correctly adjusted and is engaging with the finished floor height when the door is closed.

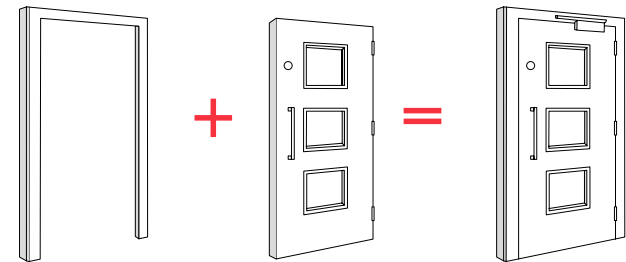

Fitting the door closer



Architrave

- Architrave can be contributory to fire performance and must be of the correct size and material compatible to the specific door assembly or doorset and installation scenario
- Only use architrave that is the correct specification as detailed on the fire door certificate
- Occasionally doors are fitted with no architrave, refer to Annex A for compatible materials and gap limitations in this scenario
- Architraves should be mechanically fixed (either pins or screws) with a minimum penetration into the sub structure of 30 mm. Architraves should be fixed at 100 mm from the corners and then at centres of 250 mm unless otherwise specified by the manufacturer

- The door closer used must be suitable for the usage class and specific door dimensions
- The door closer must be positioned correctly in accordance to the manufacturer's recommendation as incorrect positioning can cause early product failure
- Some door closers require additional intumescent protection – check the fire certificate to confirm if required and the correct specification
- The fixings for door closer will be supplied with the product. Ensure that the right fixings are used and that pilot holes are drilled at fixing points to prevent timber from splitting
- Once all fixings are applied the door closer must be adjusted to comply with opening and closing forces as stated in the Approved Document M



- Once the door closer is fully installed, perform checks to ensure the correct gaps around the doorleaf, that the doorleaf closes snugly against the doorstop and excessive force is not required to operate the door.



Backfilling the gap between the frame and the wall

Refer to Section 2 for compatible materials and specifications and installation scenarios

- Before selecting material and methods for backfilling the gap between the frame and the wall you must consider the following critical factors to ensure the correct materials and methods are used.

Backfilling the gap between the frame and the wall

- The gap behind the architrave, between the back of the frame and wall can become one of the weakest points for fire performance if it is not filled correctly
- The filling detail and materials varies depending on the fire rating of the door assembly or doorset that has been installed. It also depends on the width of the gap and the size of the architrave, the architrave material and the overlap of the architrave on both the wall and the frame. Suitable Certifire approved linear gap sealing systems may also be utilised to protect the frame / supporting construction gap, subject to the conditions contained within the relevant certificate
- Some manufacturers will give advice on the correct filling materials, methods and architrave detail because this is specific to the conditions that the door assembly or doorset was tested to. Checks should be made to ensure compatibility with the fitting scenario
- BS 8214:2016 ensures that the methods and materials used are correct. Always check the manufacturer's recommendations and suitability of filling materials

When should backfilling of the gap happen?

Only once all dimensional and functionality checks of the door has taken place, should backfilling of any gaps between the back face of the frame and the wall be done. Intumescent material and intumescent mastic as specified in the installation instructions or the fire certificate data sheet should be used to fill any gaps, and only once this installation detail has been checked, architrave should be fitted.

Suitability of gap filling materials

Consideration of the fire rating (FD30 or FD60)

The gap filling materials and methods are different for FD30 and FD60 doors, Always make checks to ensure that the correct materials and processes are used in accordance with the fire rating of the door that is installed. Suitable Certifire approved linear gap sealing systems may also be utilised to protect the frame / supporting construction gap, subject to the conditions contained within the relevant certificate.

Mastic

Mastic may only be used if it is a compatible, approved linear gap joint seal, successfully tested in accordance with BS 476-20 or BS EN 1366-4 for the required period of fire resistance.

Always check the fire certificate of backfilling materials for compatibility and limitations that will affect performance.



Expanding foam – only appropriate in limited installation scenarios

Expanding foam is widely used on construction sites, however it is not always suitable for filling the gap between the frame and wall.

- Expanding foam can only be used if they are a compatible, approved linear gap joint seal, successfully tested in accordance with BS 476-20 or BS EN 1366-4. Always check the fire certificate of backfilling materials for compatibility and limitations that will affect performance.
- Checks should be made to ensure compatible materials are used, dependent on the specific wall construction and the limitations on the gap size and requirement for additional mastic capping.

Expanding seals

Mastic and expanding foam seals may only be used if they have been included within a fire test, between the door frame and surrounding structure, on a timber-based door assembly or doorset that has demonstrated a minimum of 30 min fire resistance in accordance with BS 476-22 or BS EN 1634-1.

Always check the fire certificate of backfilling materials for compatibility and limitations that will affect performance.

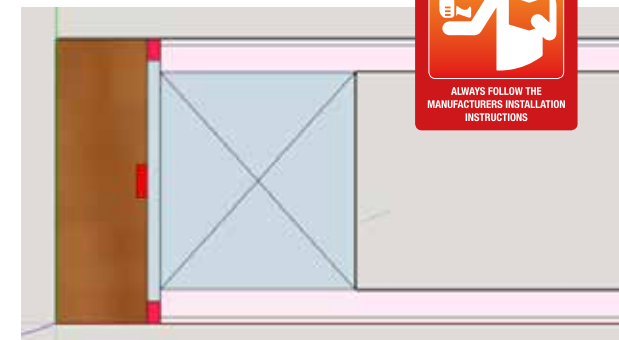

Post Installation Checklist

Door leaf	
Free from damage	<input checked="" type="checkbox"/>
Fitting plumb level and square in frame	<input checked="" type="checkbox"/>
Consistent gap between door and frame (as specified on fire certificate)	<input checked="" type="checkbox"/>
BWF-Certifire label/s on top of door undamaged	<input checked="" type="checkbox"/>
Door frame	
Free from damage	<input checked="" type="checkbox"/>
Suitable for the fire door rating	<input checked="" type="checkbox"/>
Compatible with the door assembly or doorset	<input checked="" type="checkbox"/>
BWF-Certifire label/s on top of door undamaged	<input checked="" type="checkbox"/>
Correct number of, specification, size and location of frame to wall fixings	<input checked="" type="checkbox"/>
Fire and Smoke seals	
Compatible with the door assembly or doorset	<input checked="" type="checkbox"/>
Suitable for the fire door or smoke rating	<input checked="" type="checkbox"/>
Intumescent seals are full length in door edge or frame	<input checked="" type="checkbox"/>
Seals are flush in grooves	<input checked="" type="checkbox"/>
Smoke seal fills the gap between the door and the frame on all sides	<input checked="" type="checkbox"/>
Free from damage	<input checked="" type="checkbox"/>
Compatible with the door assembly or doorset	<input checked="" type="checkbox"/>

Latch or lock	
Suitable for fire door rating	<input checked="" type="checkbox"/>
CE marked for fire performance	<input checked="" type="checkbox"/>
Engages securely with the keep in the frame or lining	<input checked="" type="checkbox"/>
Suitable for the fire door rating	<input checked="" type="checkbox"/>
Compatible with the door assembly or doorset	<input checked="" type="checkbox"/>
Fitted with correct intumescent pads if specified in the installation instructions	<input checked="" type="checkbox"/>
BWF-Certifire label/s on top of door undamaged	<input checked="" type="checkbox"/>
Hinges	
Fitted with correct intumescent pads if specified in installation instructions	<input checked="" type="checkbox"/>
Fitted with the hinge manufacturers fixings that have been supplied and fire tested	<input checked="" type="checkbox"/>
CE marked for fire performance where applicable	<input checked="" type="checkbox"/>
Fitted with correct fixings (specification and length)	<input checked="" type="checkbox"/>
All fixings in place	<input checked="" type="checkbox"/>
Free from damage	<input checked="" type="checkbox"/>
Suitable for the fire door rating	<input checked="" type="checkbox"/>
Compatible with the door assembly or doorset	<input checked="" type="checkbox"/>
Door closer (if required)	
Fitted with correct intumescent pads if specified in the installation instructions	<input checked="" type="checkbox"/>
CE marked for fire performance where applicable	<input checked="" type="checkbox"/>
Fitted with correct fixings (specification and length)	<input checked="" type="checkbox"/>
All fixings in place	<input checked="" type="checkbox"/>
Free from damage	<input checked="" type="checkbox"/>
Suitable for the fire door rating	<input checked="" type="checkbox"/>
Compatible with the door assembly or doorset	<input checked="" type="checkbox"/>



Post installation checklist continued ...

Signage	
Check that the correct signage is in place and securely fixed to the door	<input checked="" type="checkbox"/>
Other ironmongery	
CE marked for fire use on fire doors where applicable	<input checked="" type="checkbox"/>
Fitted with correct intumescent pads if specified in the installation instructions	<input checked="" type="checkbox"/>
Fitted with the ironmongery manufacturers fixings that have been supplied and fire tested	<input checked="" type="checkbox"/>
Fitted with correct fixings (specification and length)	<input checked="" type="checkbox"/>
All fixings in place	<input checked="" type="checkbox"/>
All components free from damage	<input checked="" type="checkbox"/>
Suitable for the fire door rating	<input checked="" type="checkbox"/>
Compatible with the door assembly or doorset	<input checked="" type="checkbox"/>
Vision panels or other apertures cut in the door leaf for ironmongery such as letter plates or air transfer grilles	
Check all ironmongery, glass, glazing beads, seals and intumescent materials are free from damage and secured to the door.	<input checked="" type="checkbox"/>
Check for the glazed aperture BWF-Certifire scheme label at the top of the door to prove that the door is glazed with compliant materials and glazing systems by a trained door processor.	<input checked="" type="checkbox"/>
Site cutting of apertures and on site glazing is not permitted	<input checked="" type="checkbox"/>
Gap between the wall and the frame behind the architrave	
Suitable materials and intumescent materials and mastics have been used to fill the any gap as detailed on the installation instructions or the fire certificate data sheet.	<input checked="" type="checkbox"/>

Gap	
Check gaps (top, sides, bottom, and centre) are correct to installation instructions	<input checked="" type="checkbox"/>
Wall type	
Of suitable fire resistance for the fire door assembly or doorset rating	<input checked="" type="checkbox"/>
Threshold seals	
When the door is closed the threshold seal engages fully and across its entire length	<input checked="" type="checkbox"/>
Handover of documentation to prove fire performance	
Check the BWF-Certifire label/s are in place on the top of the door and/or the frame.	<input checked="" type="checkbox"/>
Installation instructions.	<input checked="" type="checkbox"/>
Maintenance instructions.	<input checked="" type="checkbox"/>
Refer to the CF / CAF number on the label.	<input checked="" type="checkbox"/>
Fire certificate (CF) if applicable.	<input checked="" type="checkbox"/>
Contact manufacturer if further information is required.	<input checked="" type="checkbox"/>
BWF-Certifire label	
In place, correct, undamaged	<input checked="" type="checkbox"/>



Inspection and maintenance

Regular Inspection

Article 17 of the Fire Safety Order makes it a legal requirement to ensure that fire resisting doors and escape doors are correctly installed and adequately maintained in order for them to be fit for purpose.

The authorities have the power to enforce the Fire Safety Order and do prosecute or even close buildings down where breaches are discovered.

Building owners need 'competent persons' as referenced in the Fire Safety Order to help them comply with fire door regulations.



Inspection and Maintenance

Fire doors should be regularly inspected for damage that may prevent the door from performing in the event of a fire. This may form part of the risk assessment for the building.



Any issues should be fixed as soon as possible using compatible, correct fire rated components. The selection of suitable components is supported by the fire certificate and door schedule.

To check compatibility of components, always check the fire certificate data sheet or contact the fire door manufacturer.

By not using compatible components as listed on the fire certificate, fire certification of the door will be invalidated.



Further information:
<http://www.bwfcertfire.org.uk/assets/bw627-maintenance-fc.pdf>

All parts of the door assembly or doorset should be inspected by a competent person

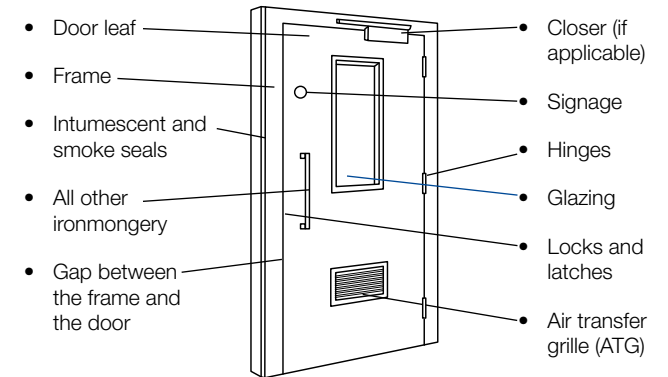

Frequency of Inspection

Periodic checks should be carried out at least once every six months.

Newly occupied buildings may require more frequent checks in the first year of use.

Doors where traffic is high are likely to be more susceptible to damage and should be checked more frequently than other doors in the building. E.g. once per week/month (depending on usage).



Sources of further information

How to measure the structural opening for a fire door assembly or doorset

Some fire door manufacturers will carry out a site survey to measure the opening in the wall and ensure that a correctly sized door and components are supplied.

However, if you are measuring the opening, the following list provides some points to consider.

Step 1: Measure the WIDTH of the aperture at the top, middle and bottom of the opening

Step 2: Measure the HEIGHT of the aperture on the left, middle and right hand side of the frame.

Step 3: Measure the depth of the opening (the wall thickness) at different points around the frame.

Other considerations: Sometimes site measuring is undertaken when the build is part way through and not all of the elements that lead to accurate dimensioning will be obvious. If you are measuring the aperture, check for finished floor heights and wall thickness. This information will also be available from architectural drawings.

Measure twice, cut once

There is no harm in checking measurements twice, prior to ordering. It will pay off in the long run.

Fitting tolerances

Once you have measured the aperture, you should subtract at least 5 mm from the smallest width measurement and 5 mm from the smallest height measurement to give a fitting tolerance.

This dimension is known as the FINISHED FRAME SIZE.

It is important to allow fitting tolerance to ensure that the frame and door can be fitted squarely and level into the aperture without bending the components.

Non square or uneven apertures

Sometimes an aperture can be uneven and measure differently. The aperture size that you specify must be the SMALLEST measurement that is taken.

You MUST NOT cut material away from the fire door frame to make it fit.

Contact information

BWF-Certifire

British Woodworking Federation Fire Door Scheme
www.bwfcertifire.org.uk

Warrington Certification

www.warringtoncertification.com/certifire.html

Fire Door Scheme Inspection

www.fdis.co.uk

Fire Door Safety Week

www.firedoorsafetyweek.co.uk

Fire door installers register

www.firedoorinstaller.co.uk

Gap Testers

BWF-Certifire Gap testers are available by contacting the British Woodworking Federation

Publications

BWF-Certifire Factcards

www.bwfcertifire.org.uk/publications/fact-cards

BWF-Certifire Scheme Directory

www.bwfcertifire.org.uk/assets/fd-scheme-directory_april15.pdf

BWF-Certifire – The Burning Issues

http://www.bwfcertifire.org.uk/assets/fire_door_guide.pdf

Guild of Architectural Ironmongers (GAI)

Code of Practice. Hardware for fire and escape doors
www.firecode.org.uk/

Downloadable checklists

BWF-Certifire have produced a series of template checklists that can be downloaded from: www.bwfcertifire.org.uk and developed for user's particular need.

- Regulation 38
- Pre installation
- Post installation
- Inspection and Maintenance
- Developers Checklist
- Merchant Checklist
- Builders Checklist



The Best Practice Guide can now be downloaded from:

www.bwfcertifire.org.uk





Contact:

The British Woodworking Federation
26 Store Street
London WC1E 7BT
0844 209 2610
firedoors@bwf.org.uk
[www. bwf.org.uk](http://www.bwf.org.uk)